

TOSHIBA BIPOLAR LINEAR INTEGRATED CIRCUIT SILICON MONOLITHIC

TA8424F

3 PHASE HALL MOTOR DRIVER IC

The TA8424F is non switching type 3 Phase Hall Motor Driver IC consisted of FG Amplifier, Regulator for Hall Sensors, control Amplifier and 3 Phase Output Drivers.

FEATURES

- Low Noise (Quasi Sinusoidal Drive), Current Control Motor Driver.
- Low Output Impedance with B Class Push-Pull Driver.
- Output Current Up to 1.2A.
- Operating Voltage Range : $V_{CC} = 7 \sim 17V$
- Built-in Thermal Shutdown Circuit, FG Amplifier and Regulator.
- 2 Brake Modes Available (Short Brake and Dumping Brake).
- Build in regulator for Hall Sensors.

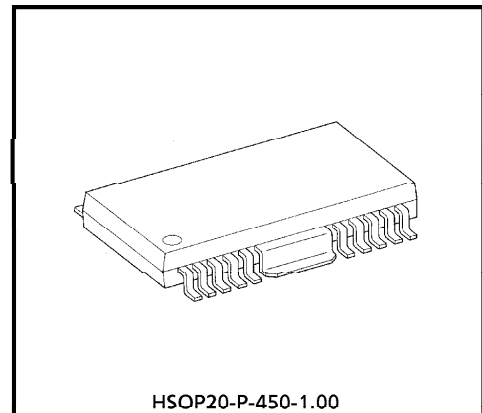

Weight : 0.79g (Typ.)

961001EBA1

- TOSHIBA is continually working to improve the quality and the reliability of its products. Nevertheless, semiconductor devices in general can malfunction or fail due to their inherent electrical sensitivity and vulnerability to physical stress. It is the responsibility of the buyer, when utilizing TOSHIBA products, to observe standards of safety, and to avoid situations in which a malfunction or failure of a TOSHIBA product could cause loss of human life, bodily injury or damage to property. In developing your designs, please ensure that TOSHIBA products are used within specified operating ranges as set forth in the most recent products specifications. Also, please keep in mind the precautions and conditions set forth in the TOSHIBA Semiconductor Reliability Handbook.
- The products described in this document are subject to foreign exchange and foreign trade control laws.
- The information contained herein is presented only as a guide for the applications of our products. No responsibility is assumed by TOSHIBA CORPORATION for any infringements of intellectual property or other rights of the third parties which may result from its use. No license is granted by implication or otherwise under any intellectual property or other rights of TOSHIBA CORPORATION or others.
- The information contained herein is subject to change without notice.

BLOCK DIAGRAM

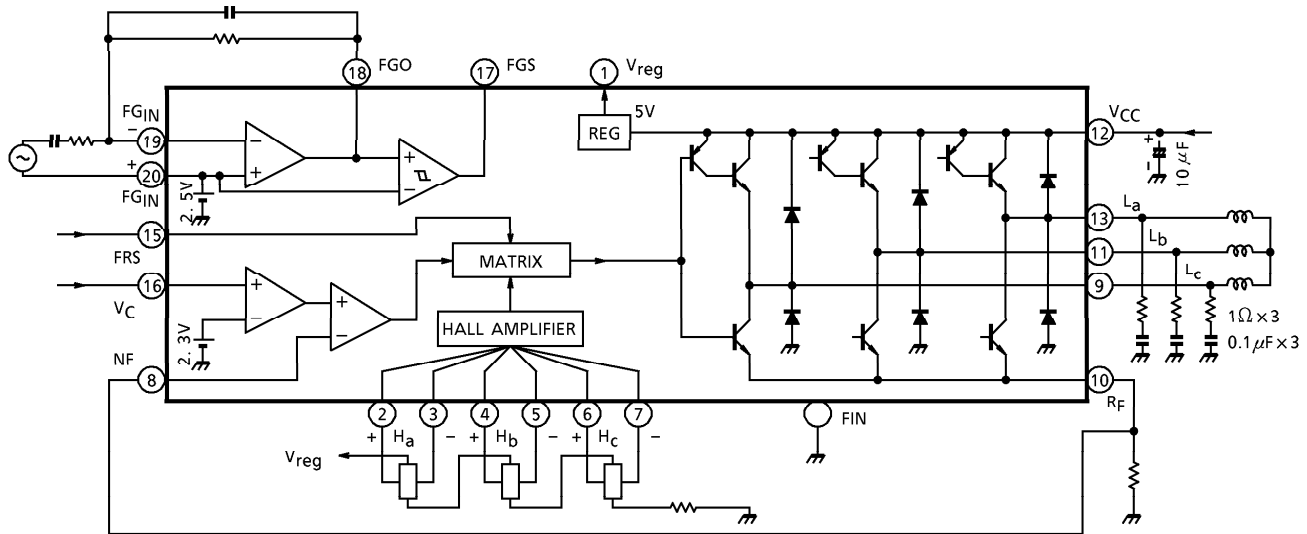

PIN FUNCTION

PIN No.	SYMBOL	FUNCTIONAL DESCRIPTION
1	V _{reg}	Internal power supply output terminal.
2	Ha ⁺	a-phase Hall-Amp positive input terminal.
3	Ha ⁻	a-phase Hall-Amp negative input terminal.
4	Hb ⁺	b-phase Hall-Amp positive input terminal.
5	Hb ⁻	b-phase Hall-Amp negative input terminal.
6	Hc ⁺	c-phase Hall-Amp positive input terminal.
7	Hc ⁻	c-phase Hall-Amp negative input terminal.
8	NF	Feedback resistance connection terminal.
9	L _c	c-phase drive output terminal.
10	R _F	Output current detection terminal.
11	L _b	b-phase drive output terminal.
12	V _{CC}	Power supply input terminal.
13	L _a	a-phase drive output terminal.
14	N.C.	Non connection.
15	FRS	Forward / Reverse control terminal.
16	V _C	Control signal input terminal.
17	FGS	Hysteresis Amp. output terminal.
18	FGO	FG Amp. output terminal.
19	FG _{IN} -	FG Amp. negative input terminal.
20	FG _{IN} +	FG Amp. positive input terminal.
	FIN	GND terminal.

OPERATING MODE

MODE	FRS	V_C	OUTPUT
Forward	L	$V_C > 2.3V$	$L_a = H_a - H_b$ $L_b = H_b - H_c$ $L_c = H_c - H_a$
Reverse	H	$V_C > 2.3V$	$L_a = -(H_a - H_b)$ $L_b = -(H_b - H_c)$ $L_c = -(H_c - H_a)$
Stand-By	M	—	Center (Note)
Brake	—	$V_C < 2.3V$	Center (Note)

(Note) Low Impedance

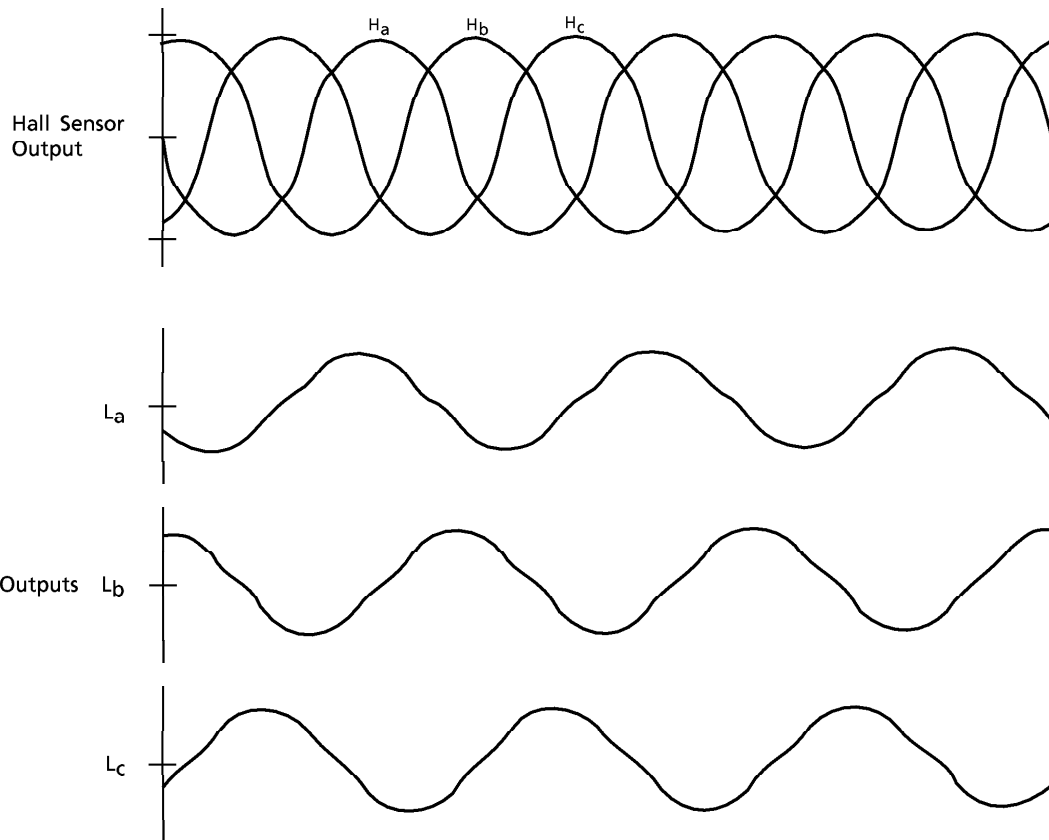

1. Control Gain (G_{VCO})

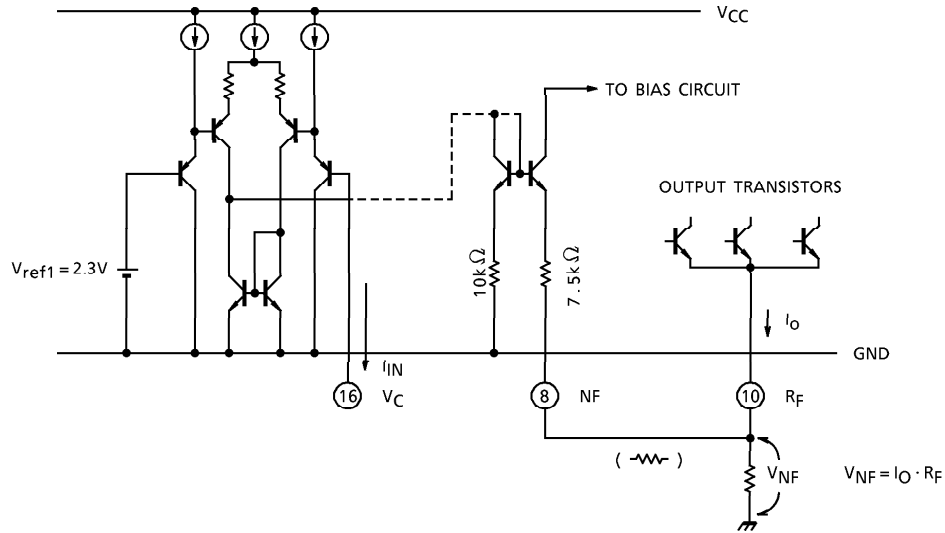

Negative Feedback is looped by R_F and connected its line to pin⑧.
 Feedback Voltage V_{NF} is generated by R_F and Output Current I_O .
 It is possible to decrease the feedback by connecting a resistor between pin⑩ and pin⑧.
 Input current of V_C ($I_C I_N$) vs V_C characteristic is shown below.

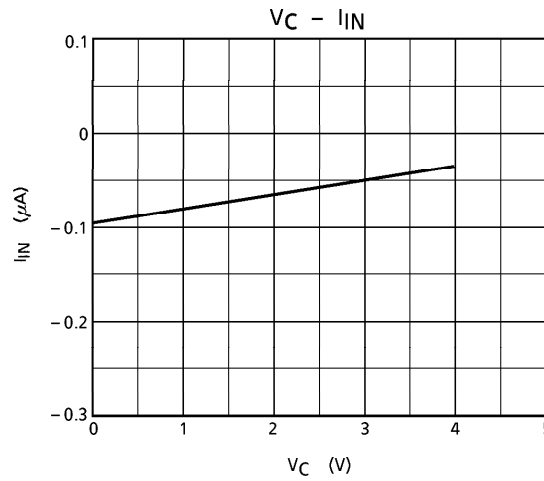

2. FG Amplifier and Hysteresis Amplifier

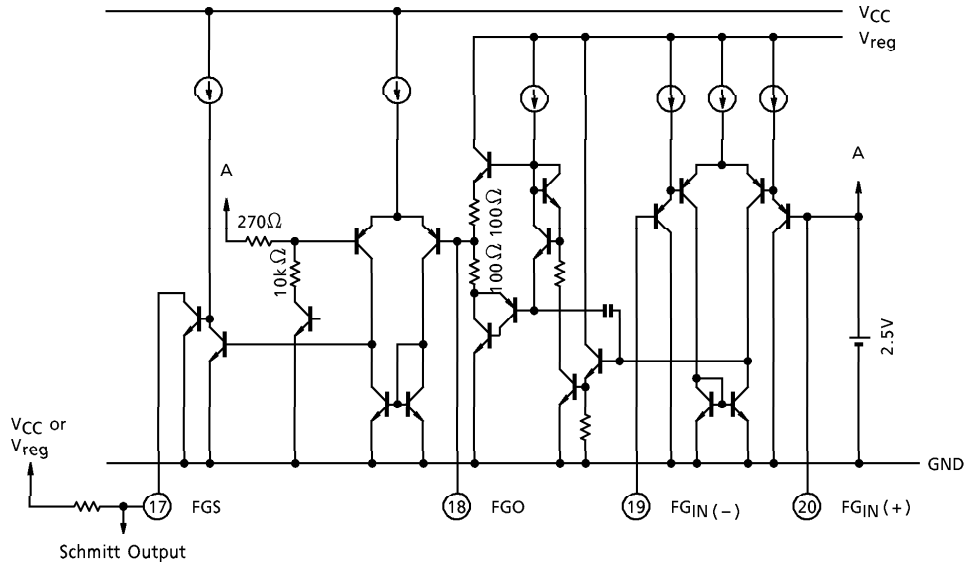

2.5V of Internal Reference is equipped with FG Amplifier. FG signal is fed into FG_{IN+} and FG_{IN-} inputs with differential mode and outputs to FGO (Pin¹⁸).

Amplified FG signal is wave shaped by Hysteresis Amplifier in following stage and outputs a wave shaped signal to FGS (Pin¹⁷).

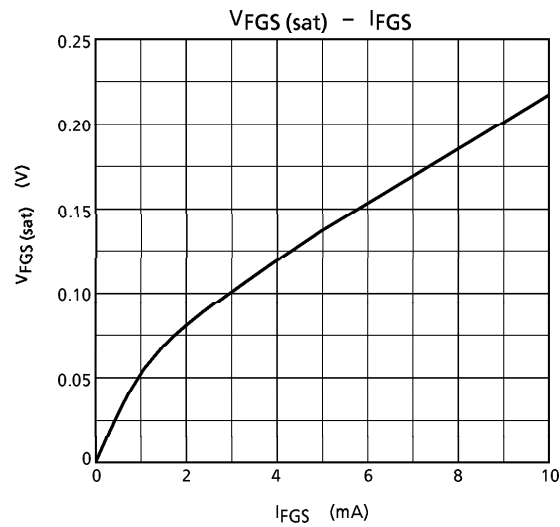

3. Regulator (V_{reg})

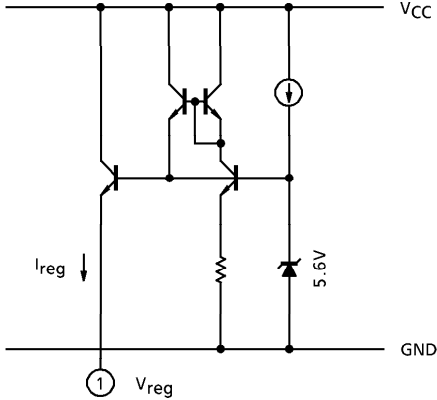

Internal regulator outputs 5V and this current capability is up to 30mA. V_{CC} vs V_{reg} characteristic is shown below.

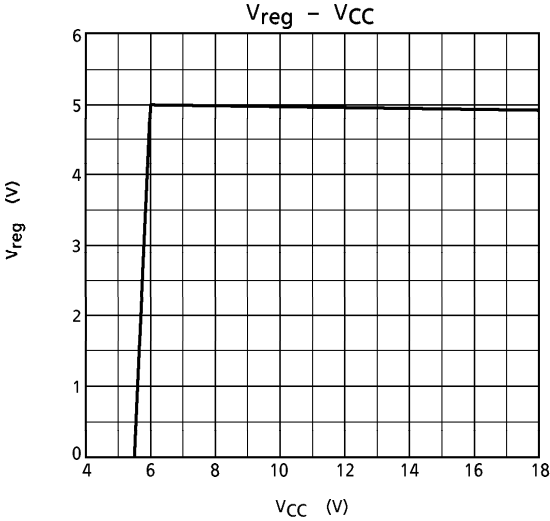

4. FRS input (Rotation direction and stop control)

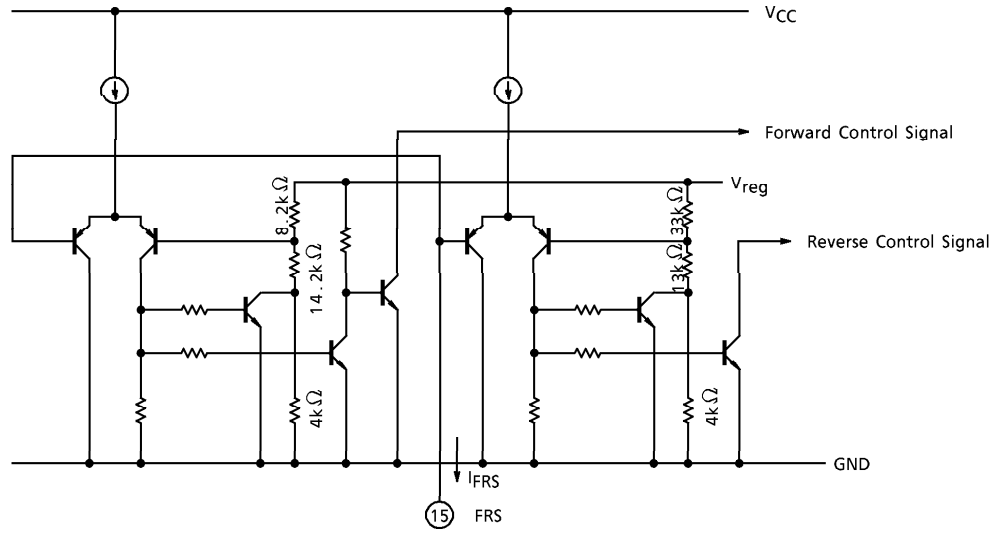

FRS input is a control terminal of Motor Rotation Direction and Stop.
 V_{FRS} vs I_{FRS} characteristic is shown below.

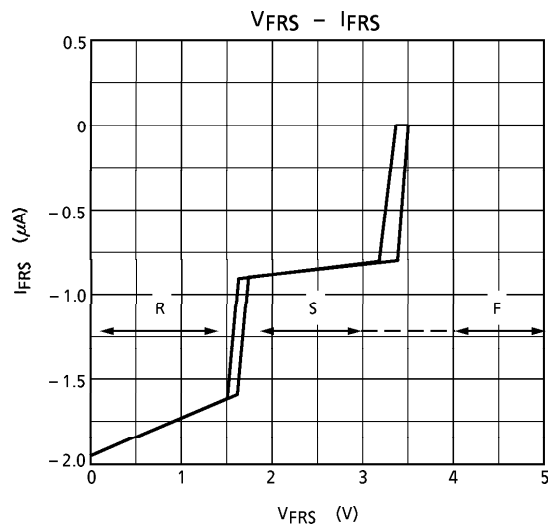

MAXIMUM RATINGS (Ta = 25°C)

CHARACTERISTIC	SYMBOL	RATING	UNIT
Supply Voltage	V _{CC}	18	V
Output Current (Average)	I _O (MAX.)	1.2	A
FG Output Current	I _{FGO}	12	mA
	I _{FGS}	14	
Power Dissipation	P _D	1.0 (Note 1)	W
		3.2 (Note 2)	
		5.8 (Note 3)	
Operating Temperature	T _{opr}	-30~75	°C
Storage Temperature	T _{stg}	-55~150	°C

(Note 1) No Heat Sink
 (Note 2) 50×50×1mm Fe board, Mounting
 (Note 3) T_c = 75°C

ELECTRICAL CHARACTERISTICS (V_{CC} = 12V, Ta = 25°C)

CHARACTERISTIC		SYMBOL	TEST CIRCUIT	TEST CONDITION	MIN.	TYP.	MAX.	UNIT
Supply Current		I _{CC 1}	—	Output open, FRS = 2.5V	—	12.5	25	mA
		I _{CC 2}	—	Output open, FRS = GND	—	14	25	
		I _{CC 3}	—	Output open, FRS = 5V	—	14	25	
Rotation Control Circuit	Control Gain (V _C →Out)	G _{VCO}	—	V _{CC} = 12V, V _H = 50mV _{p-p}	7.5	13	18	dB
	Input Current (V _C)	I _{CIN}	—	V _C = GND (Sink current)	—	0.2	5	μA
	Internal Reference-1	V _{ref 1}	—	—	2.15	2.30	2.45	V
Position Sensing Circuit	Common Mode Range	CMR _H	—	—	1.5	—	5	V
	Input Current	I _H	—	V _{IH} = 2.5V	—	0.2	3	μA
	Voltage Gain (Each Hall Input to OUT)	G _{VHO}	—	V _C = 5V, V _{CC} = 12V	40	47	51	dB
Output Driver	Upper Side Saturation	V _{sat (U)}	—	I _O = 1.0A	—	1.2	1.9	V
	Lower Side Saturation	V _{sat (L)}	—	I _O = 1.0A	—	0.7	1.5	
	Quiescent Voltage	V _{OS}	—	V _C = 1.0V	5.0	5.5	7.0	V
	Quiescent Voltage Difference	V _{OOF}	—	Each output to output	—	25	50	mV
FG Amp	Open Loop Gain	G _{VFG}	—	f _{FG} = 1kHz	—	70	—	dB
	Band Width	f _{FG}	—	—	DC	—	50	kHz
	Output Voltage Swing	V _{FGO}	—	I _{FGO} = 5mA	1.0	2.1	4	V
	FGS Saturation	V _{sat (FGS)}	—	I _{FGS} = 4mA	—	0.15	0.25	V
	Internal Reference-2	V _{ref 2}	—	—	2.1	2.5	2.9	V
	Hysteresis Voltage	V _{HYS}	—	—	—	100	250	mV
Rotation Direction Control	FWD	Operating Voltage	V _{FWD}	—	4.0	—	V _{CC}	V
	STOP	Operating Voltage	V _{STOP}	—	1.9	—	3.1	V
	REVERSE	Operating Voltage	V _{REV}	—	0	—	1.3	V
Regulator Output Voltage		V _{REG}	—	I _H = 10mA	4.7	5.1	5.5	V
Thermal Shutdown Operating Temperature		T _{SD}	—	—	150	—	—	°C

Output Amplifier Saturation Voltage Characteristics

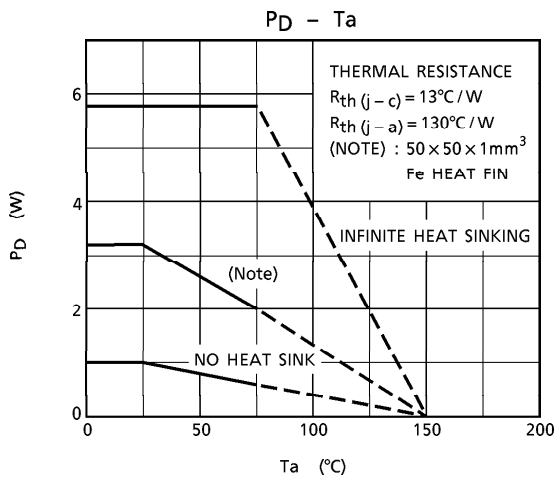
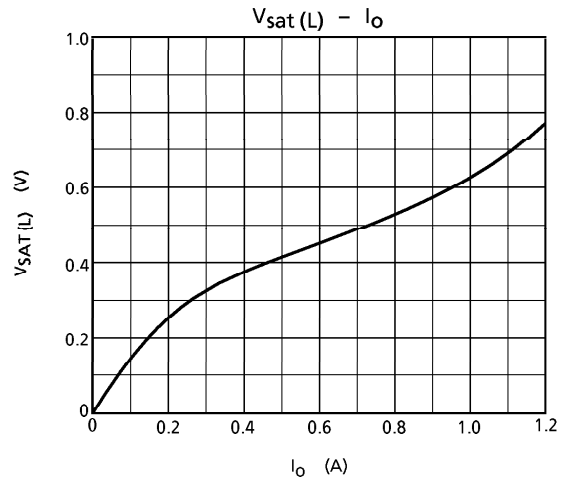
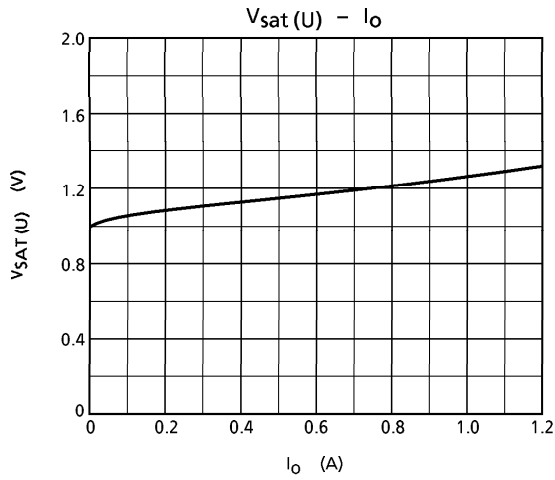

APPLICATION CIRCUIT

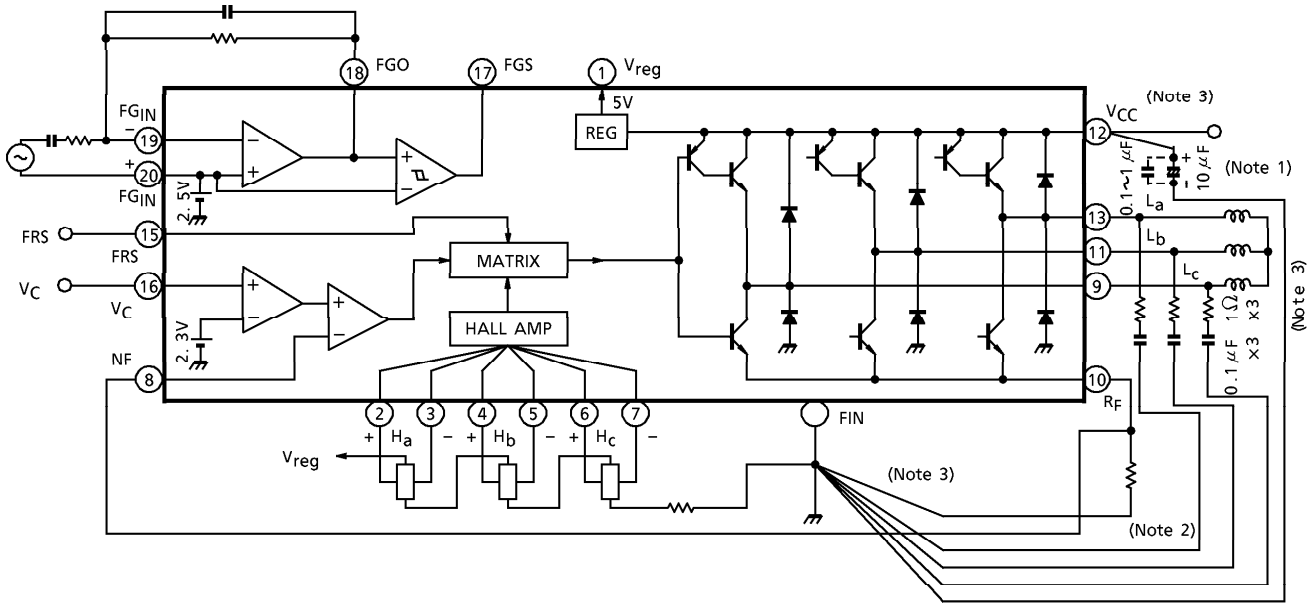

- (Note 1) Connect if required (0.1~1 μ F)
- (Note 2) Care should be taken not to have common impedance between R_F GND Line and other small signal lines for stable operations (especially for Hall Sensor GND line).
- (Note 3) Utmost care is necessary in the design of the output line, V_{CC} and GND line since IC may be destroyed due to short-circuit between outputs, air contamination fault, or fault by improper grounding.

OUTLINE DRAWING

HSOP20-P-450-1.00

Unit : mm

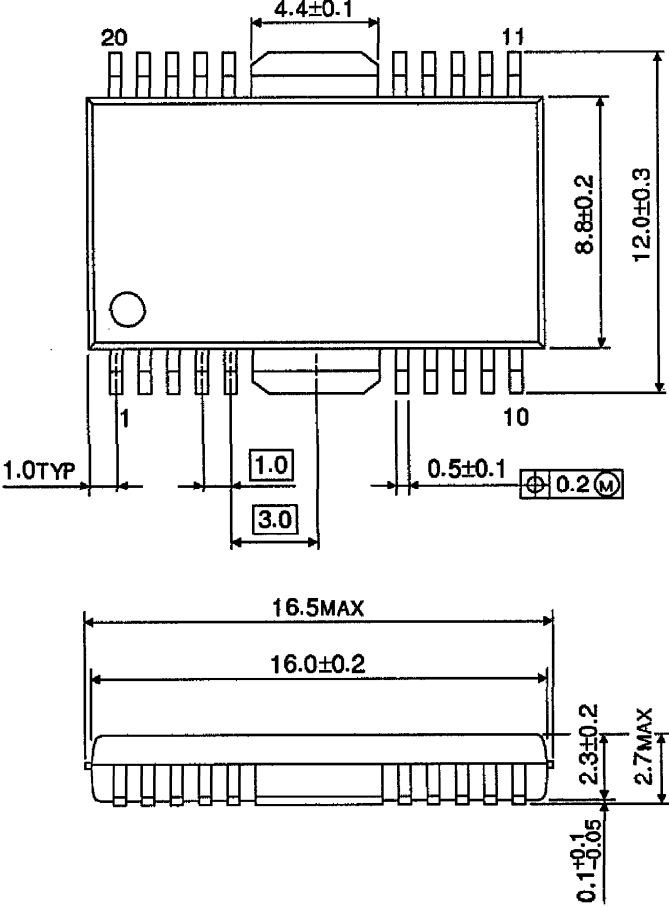

Weight : 0.79g (Typ.)